

MP80xx Image Platform Quick Guide

Notice

- ☞ A standard packing includes an image platform, a 5V adaptor, a USB cable and a CD (or a user manual).
- ☞ Accessories include a stand, a RS232 cable and a PS2 cable.
- ☞ Use a piece of dry and soft cloth when cleaning the image platform is in need.

Parts of the scanner

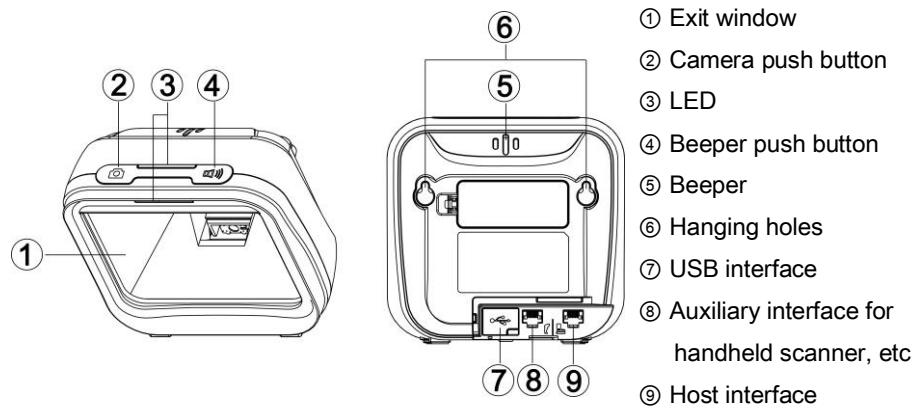

Returning default parameters and listing version information



Default value initialization



Firmware version list

Scan mode (Alternative)



Good-read off (Default)



Timeout off

Installing the cable

1. Switch off the host system;
2. Refer to the below pictures, connect the host with the image platform based on different cables;
3. Ensure that all connections are secure.
4. Switch on the host system. If the installation is successful, the beeper will beep and LED will light.



PS2 cable

RS232 cable

USB cable

Programming instruction and example

Two programming modes have been provided as bellows:

➤ Single-scan setting

Scan the appropriate barcode on the right.



Example: to set **Flow control** to be XON/XOFF.

➤ Multiple-scan setting

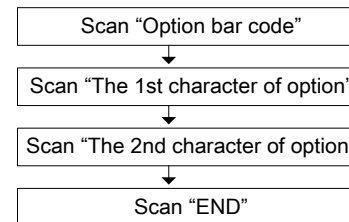

Example: to set **Flow control** to be XON/XOFF.

Reading techniques

1. Move the barcode to close to the image platform.
2. In general, the reading range of the image platform is limited to 2-8cm regardless of the size of the minimal element of the barcode.
3. On a successful reading, the beeper will beep and the LED will light. If no barcode closes to the image platform in a moment, the image platform will go to sleep.

Field of view

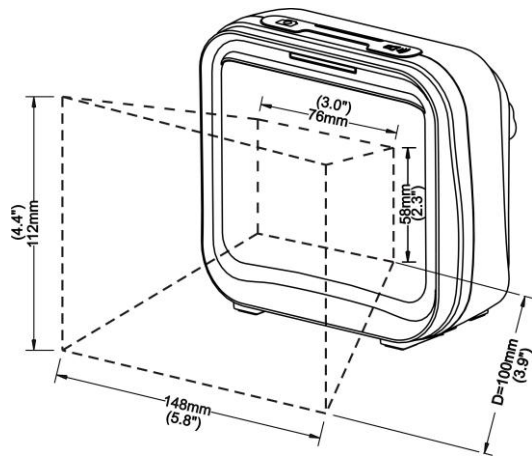

Figure 1-1 Field of view

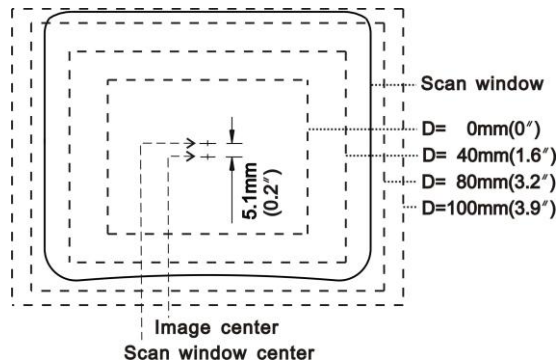

Figure 1-2 Field of view – Front view

Assembling the stand

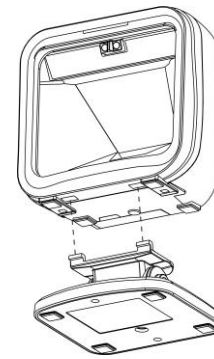

Figure 2-1

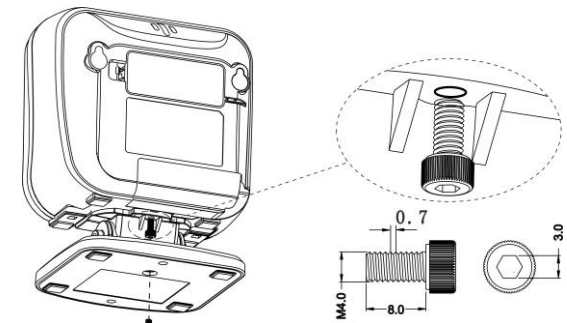

Figure 2-2

SCALE 5: 1

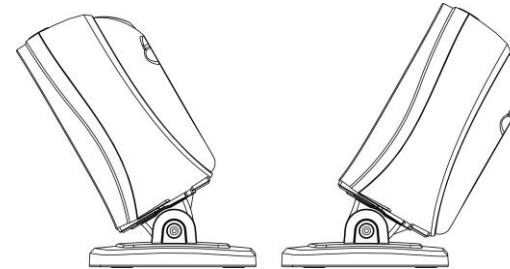

Figure 2-3



Figure 2-4

1. As shown in Figure 2-1, plug in two connection-arms to the two associated notches on the bottom of the image platform.
2. As shown in Figure 2-2, well connect the image platform with the stand by tightening the single screw.
3. As shown in Figure 2-3, adjust the image platform forward/backward for a desired position.
4. As shown in Figure 2-4, if you want to fix the stand on a table or other platform, you can remove two plastic stopper on the stand (see ①), then fix the stand with a table with appropriate screws.